

FITTING INSTRUCTIONS – NOTICE DE POSE – MONTAGE HANDLEIDING – MONTAGEANLEITUNG

ISTRUZIONI DI MONTAGGIO – INSTRUCCIONES DE MONTAJE

**System Specification**

<b>Maximum Door Width = 1200mm</b>	<b>Minimum Door Width = 500mm</b>
<b>Door Thickness Range = 32 &gt; 47mm</b>	<b>Maximum Weight per Leaf = 80kg</b>

**Contents of Kit**

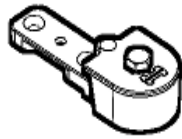

2 x Short Arm



4 x Belt joint



4 x Belt retain



10 x Belt clamp

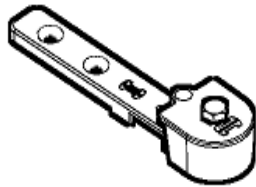

2 x Long arm



2 x Fixed floor guide



2 x Adjustable floor guide



2 x Adjustable floor guide bracket

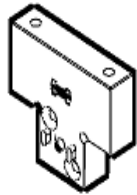

2 x Datum Block

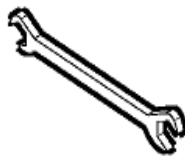

1 x Spanner



8 x Husky hanger



8 x Apron plate

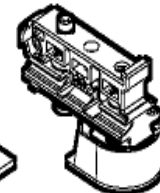

2 x Tension wheel

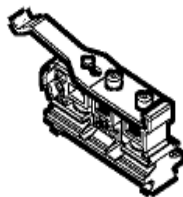

2 x Universal clip stop



Toothed belt (Meters)

x 16 m

	80/4
M8x40 Hex HD bolt	8
M8 Flanged nut	8
M8 Full Nut	8
M6x12 CSK HD	10
M6x10 CSK HD	8
8Gx38 Woodscrews	16
4.5x30 Woodscrews	26
M4x6 Grubscrews	2

## Tools required



Tape  
Measure



2, 3, 4 & 5 mm  
Allen keys



Posi head  
screwdriver

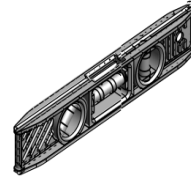

Spirit level



Scissors

## System overview & track installation

FOLLOWER DOORS

LEAD DOORS

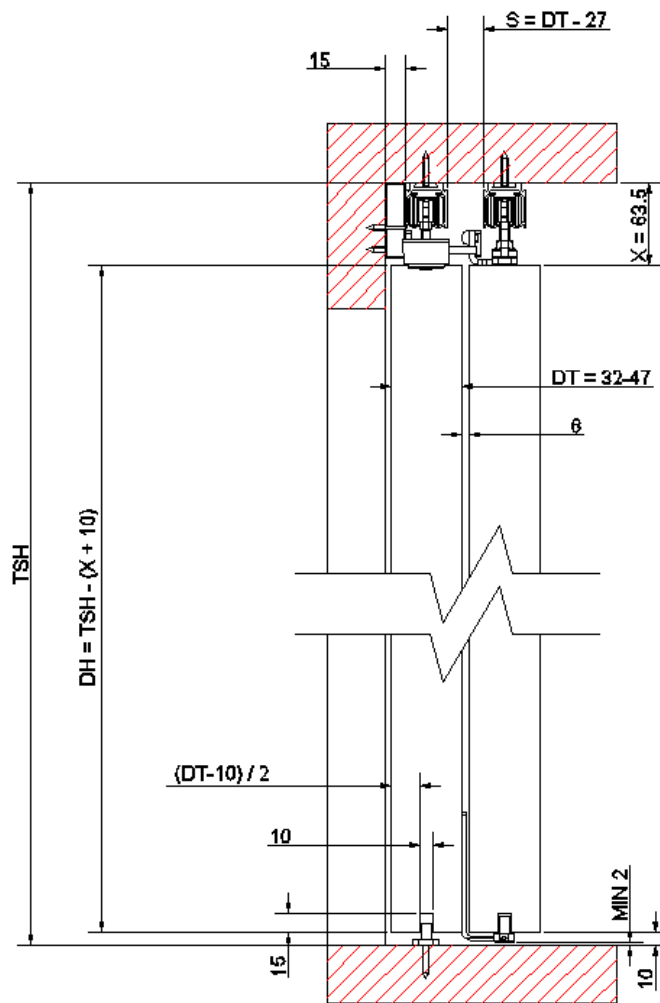

### KEY

DT = DOOR THICKNESS

TSH = TRACK SET HEIGHT

DH = DOOR HEIGHT

S = GAP REQUIRED BETWEEN  
TRACKS

X = PCH RECOMMENDED TOP  
CLEARANCE (63.5mm)

## Door component layout

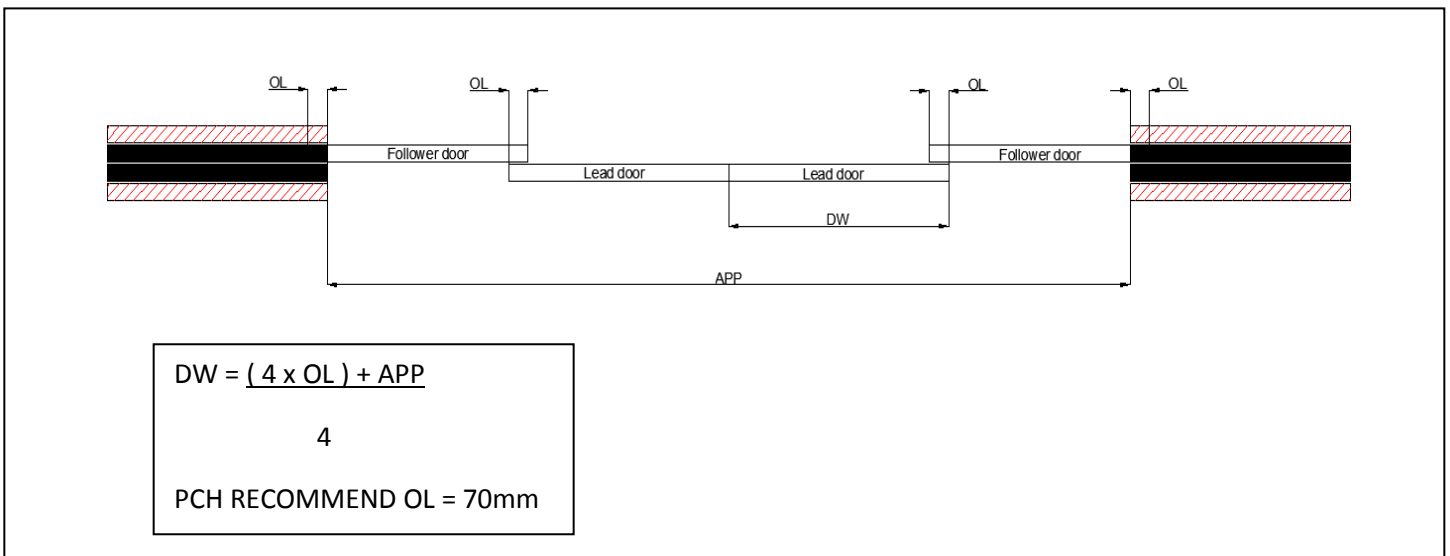
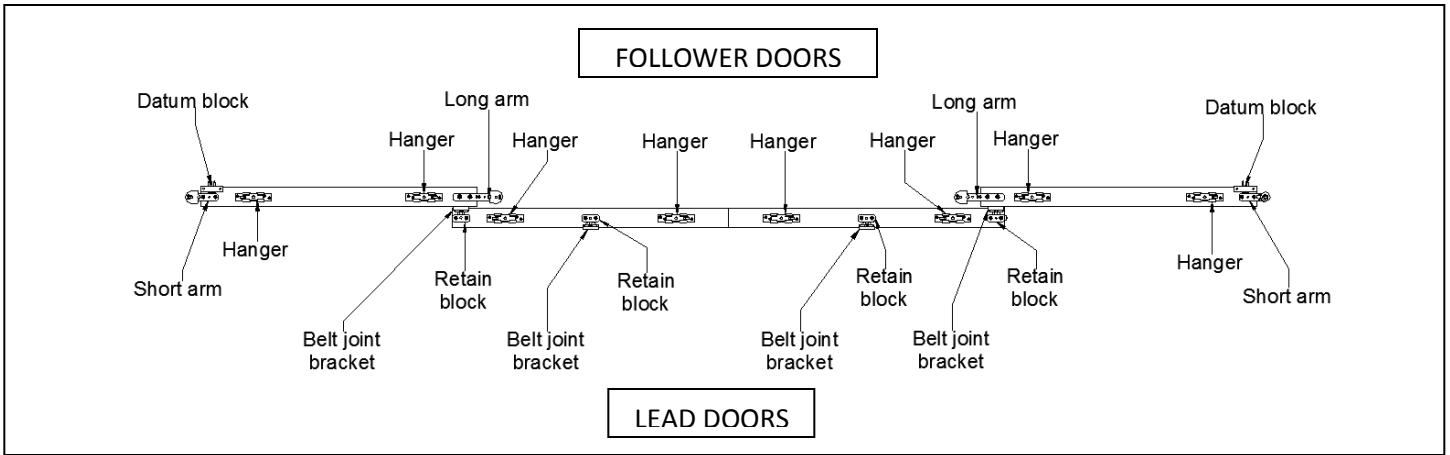

### KEY

DW = DOOR WIDTH

APP = MAXIMUM CLEAR OPENING WIDTH

OL = OVERLAP OF DOORS (RECOMMENDED 70mm)

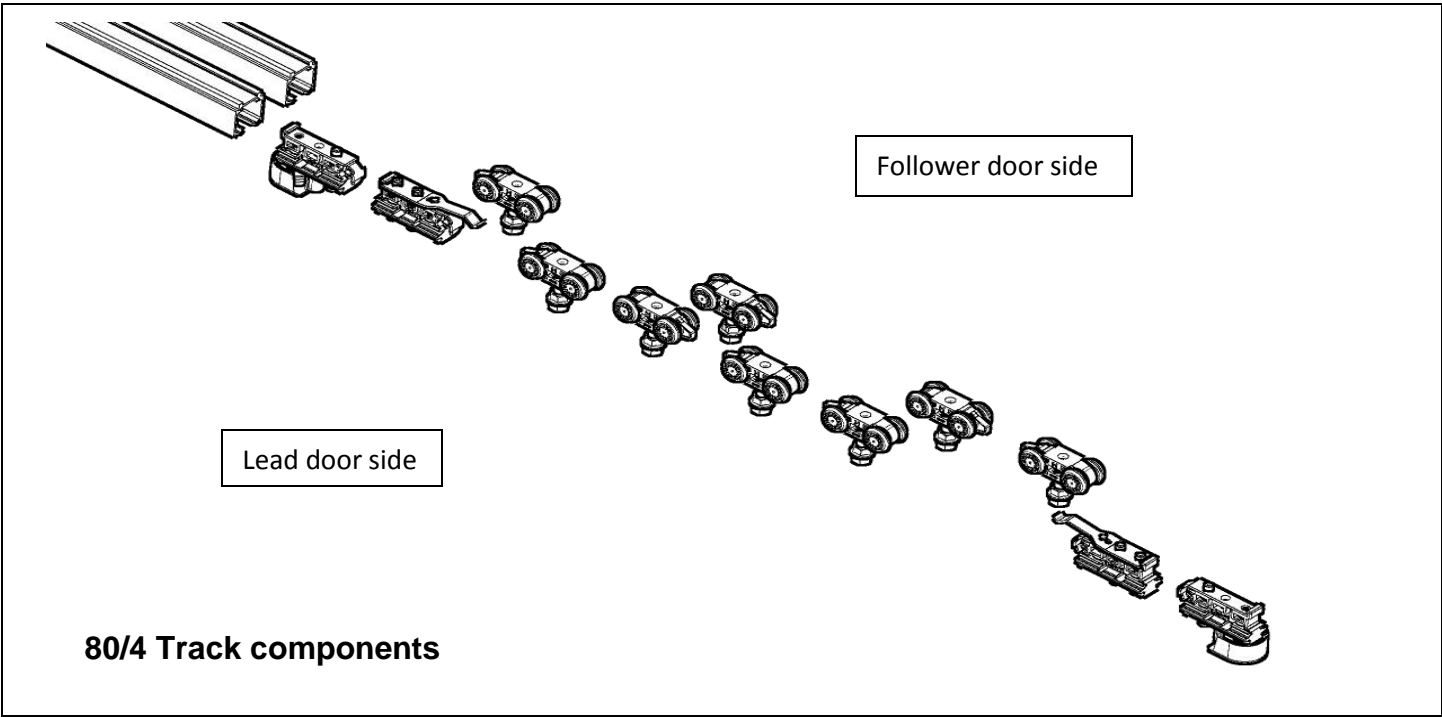

Door Floor guide routing detail

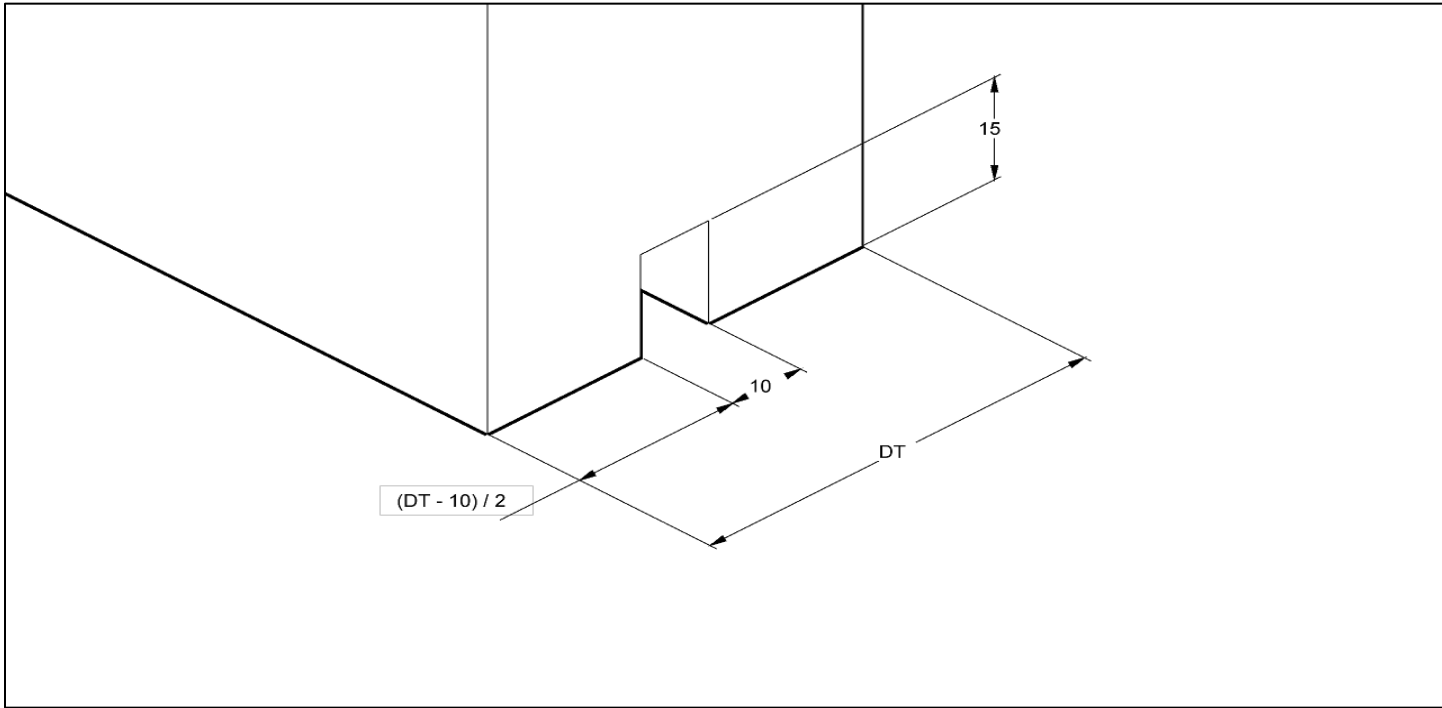

1. Attach apron plates (All Doors)

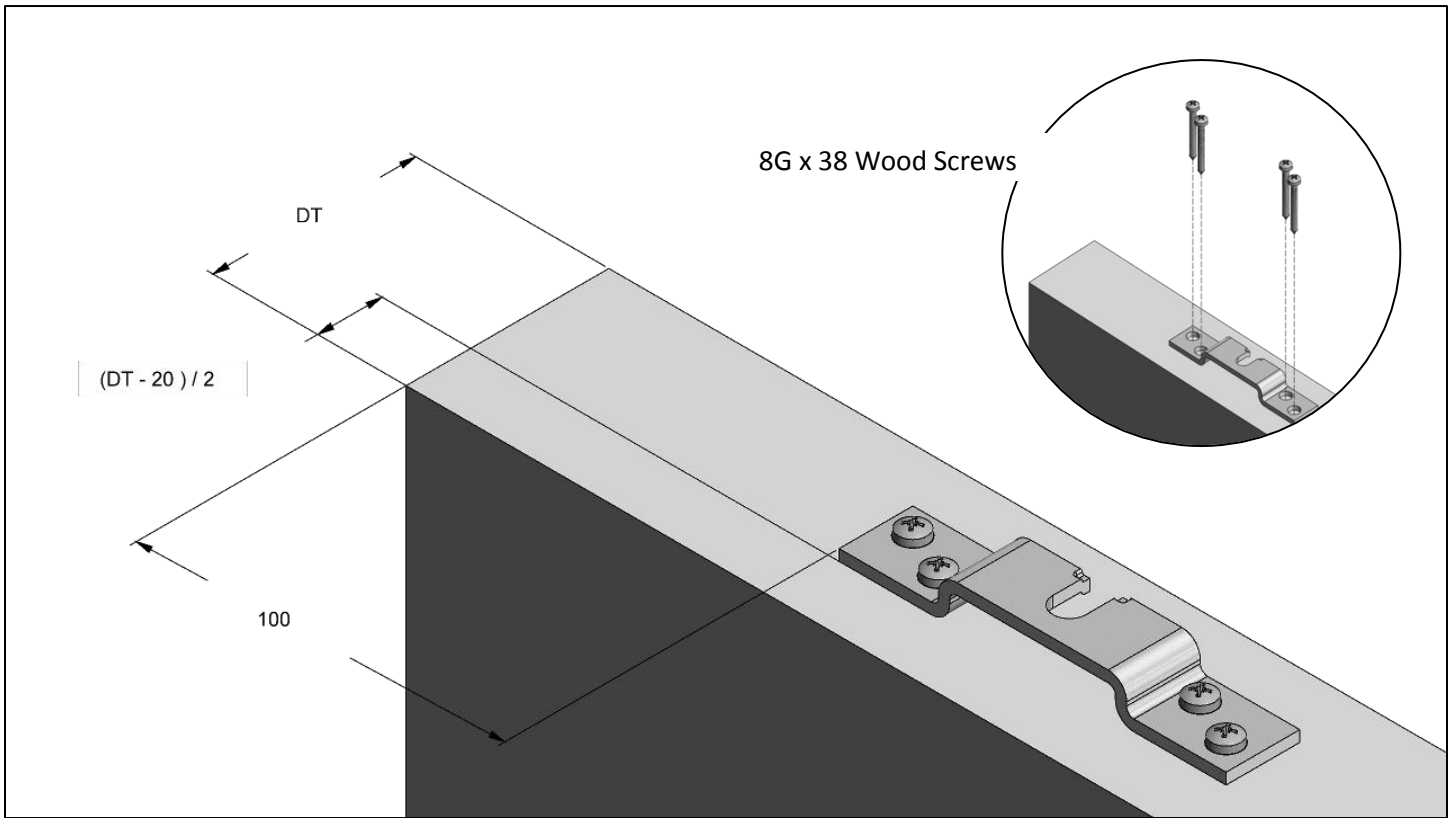

2. Attach Long arm on following doors

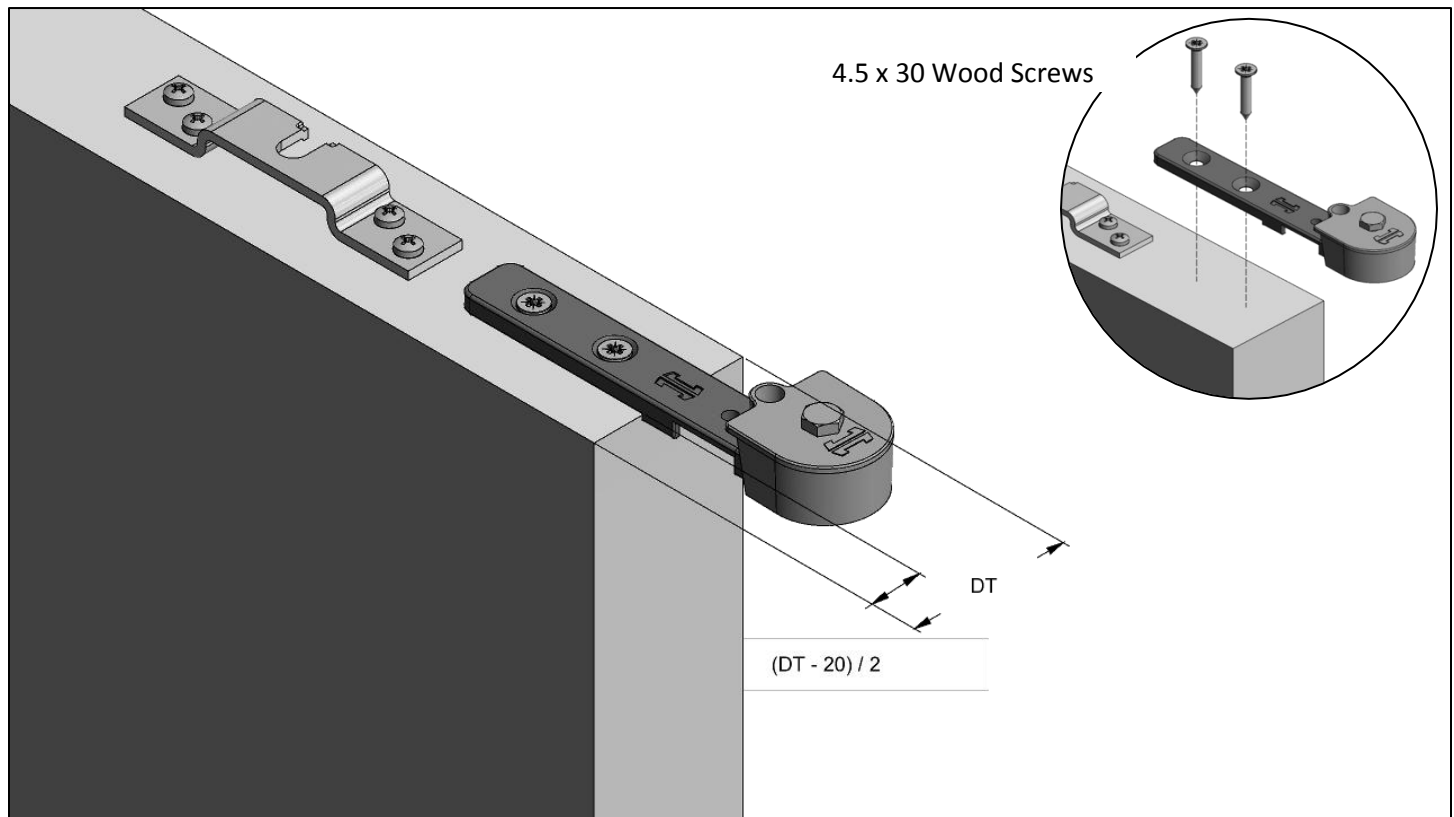

### 3. Attach Short arm to follower doors

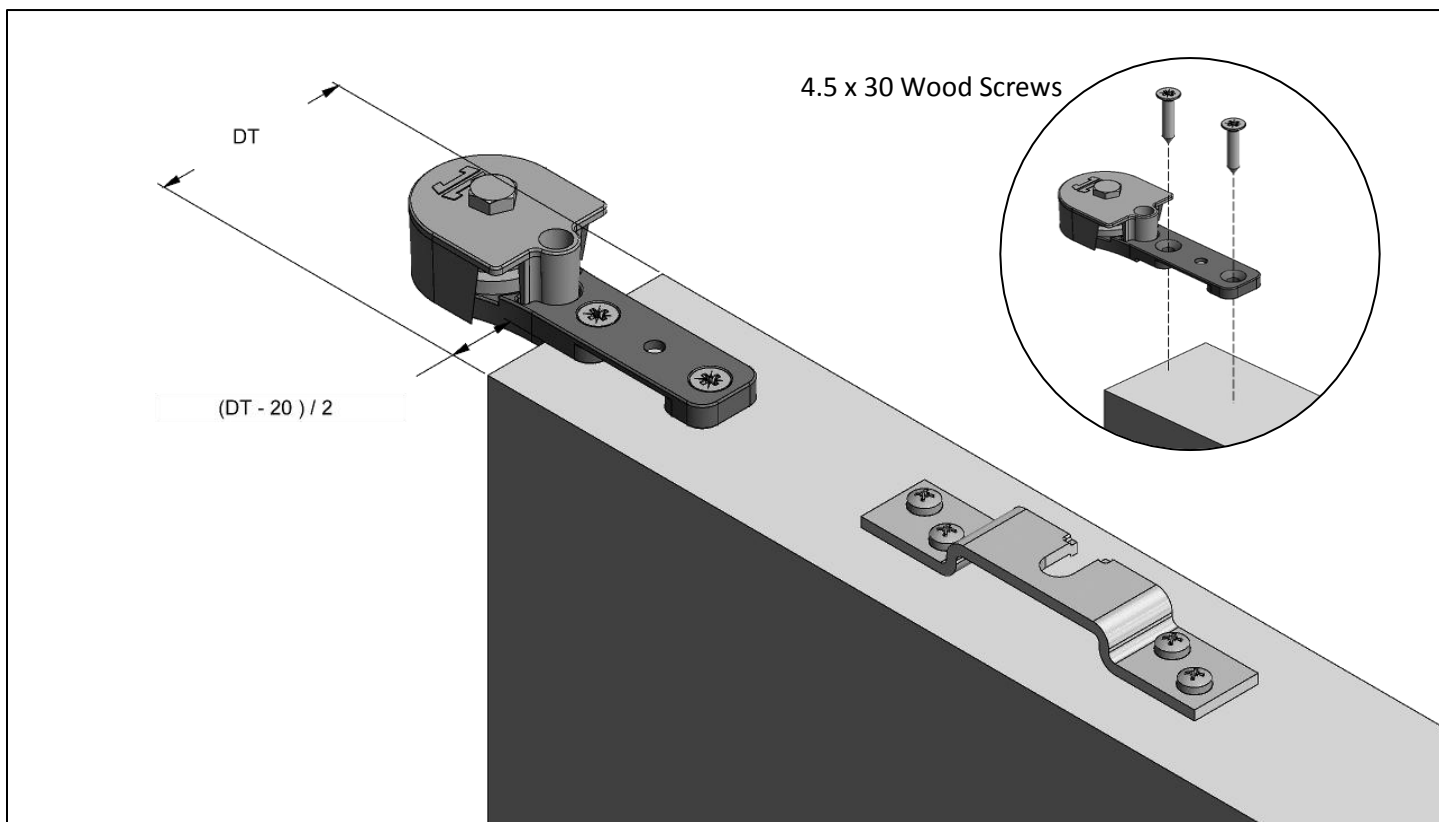

### 4. Remove bearing caps on follower doors

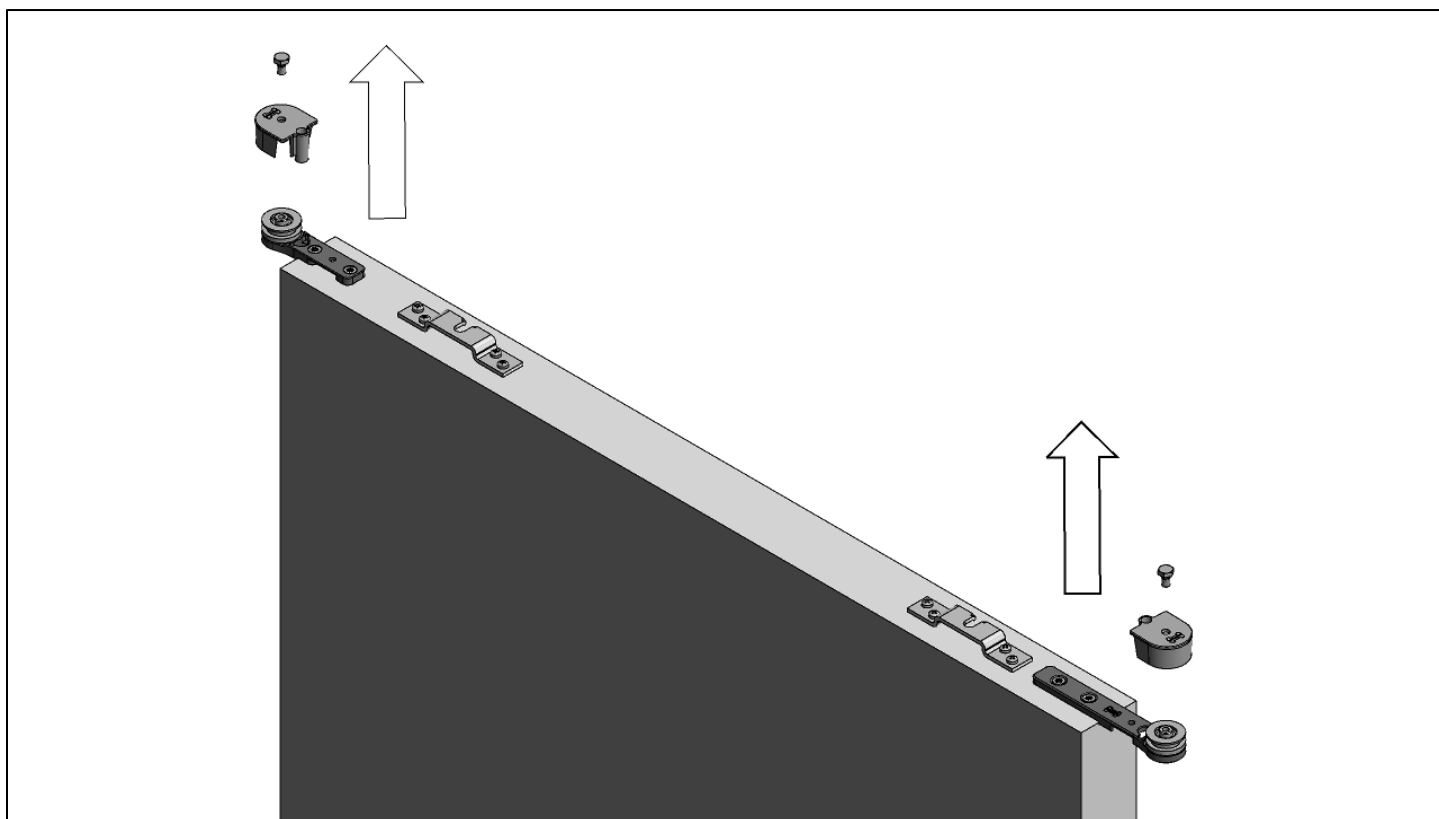

5. Loop belt around bearing wheels & cut belt to length – on follower doors

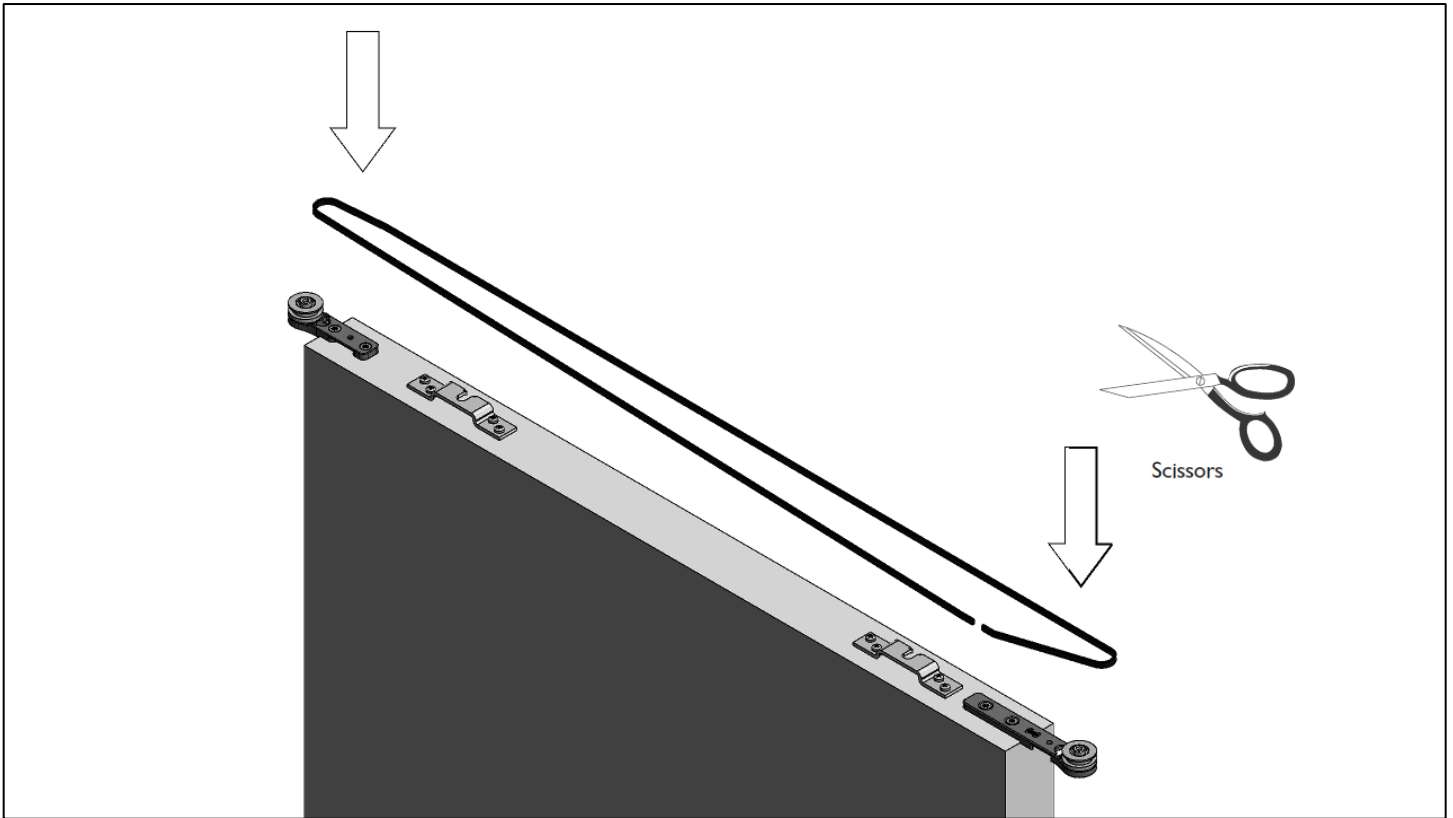

6. Attach both ends to belt joint bracket – on follower doors

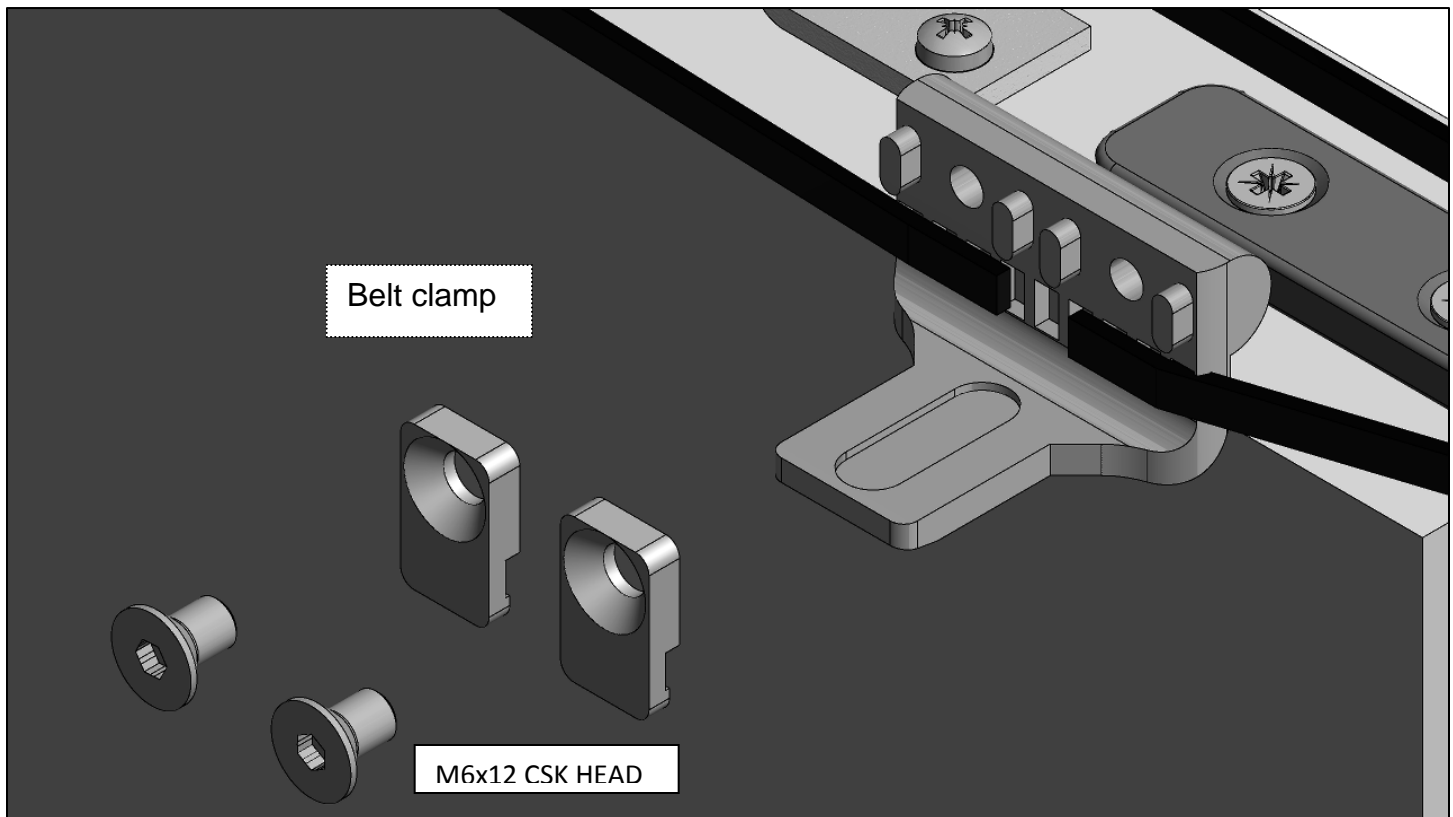

7. Clamp bracket should be free to traverse between bearings – on follower doors

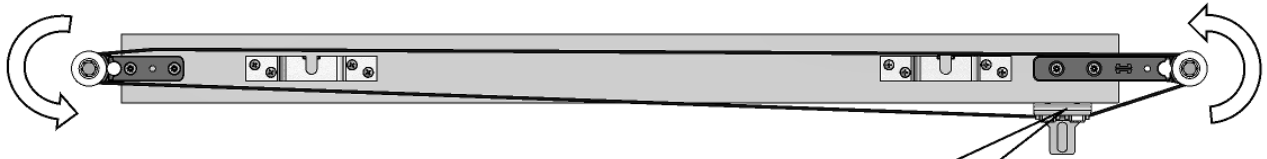

**IMPORTANT**

Belt tension should be sufficient to allow connection between doors

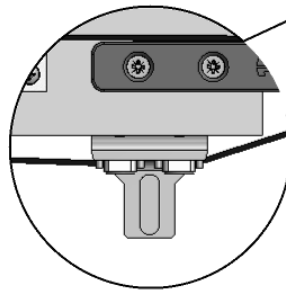

Approx 10 > 20 mm  
depending upon  
door thickness

8. Re attach bearing caps

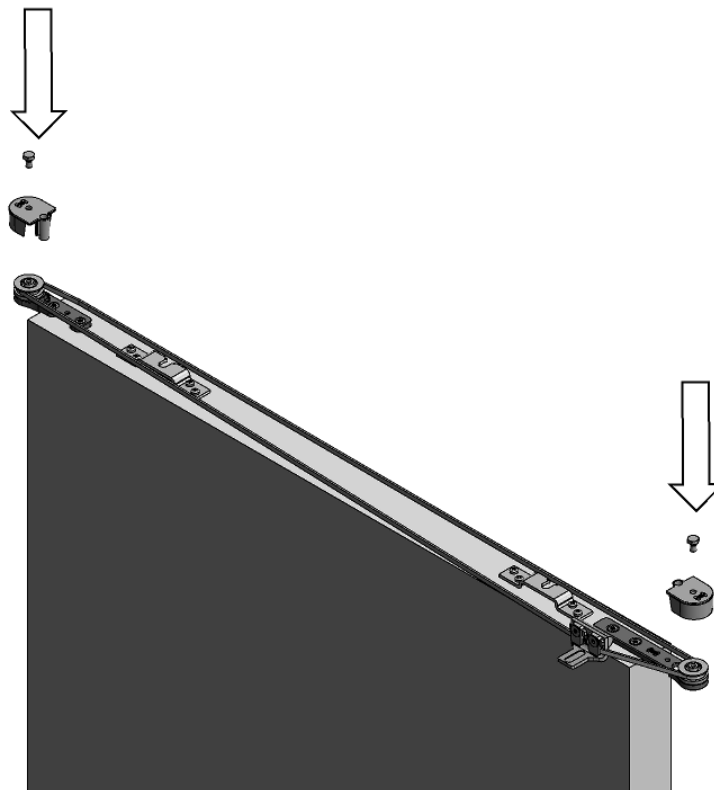



## 9. Lead door fixings overview (LH VIEW SHOWN)

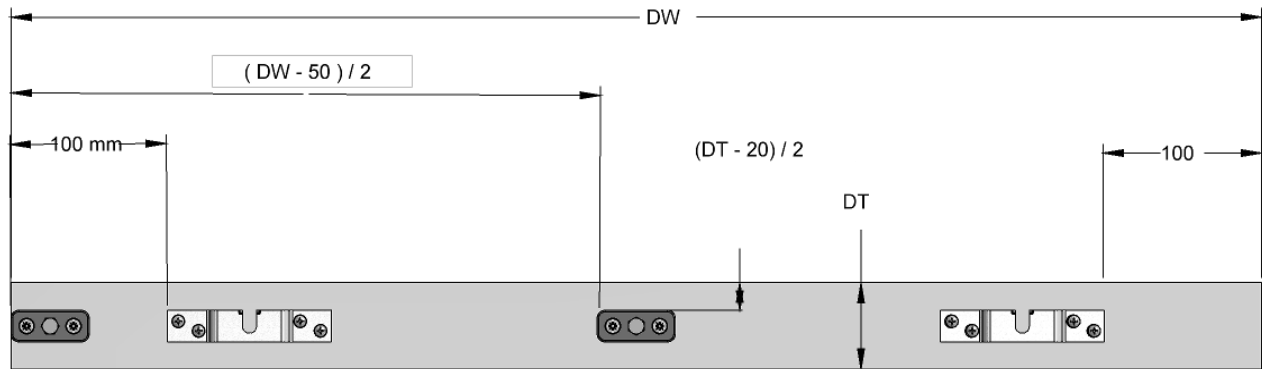

## 10. Position retain block on lead doors

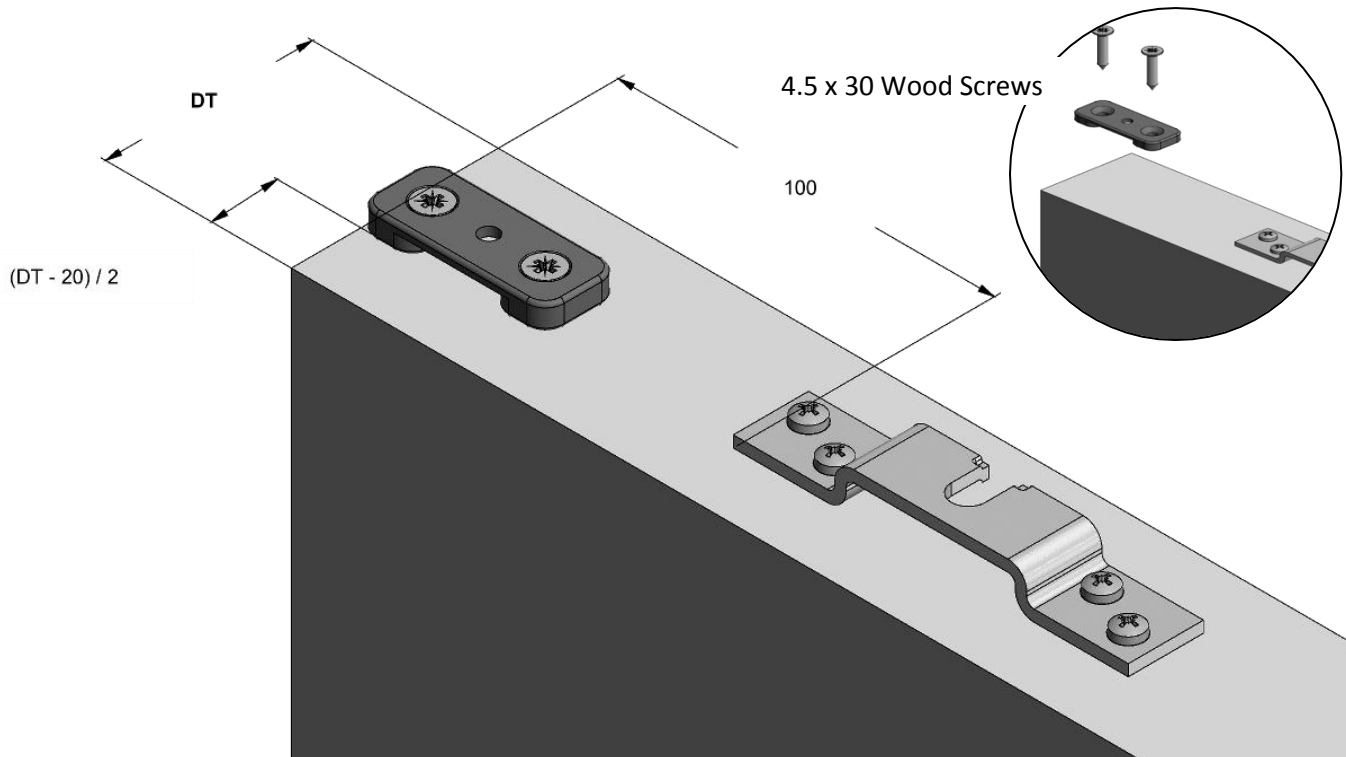

## 11. Floor guide overview

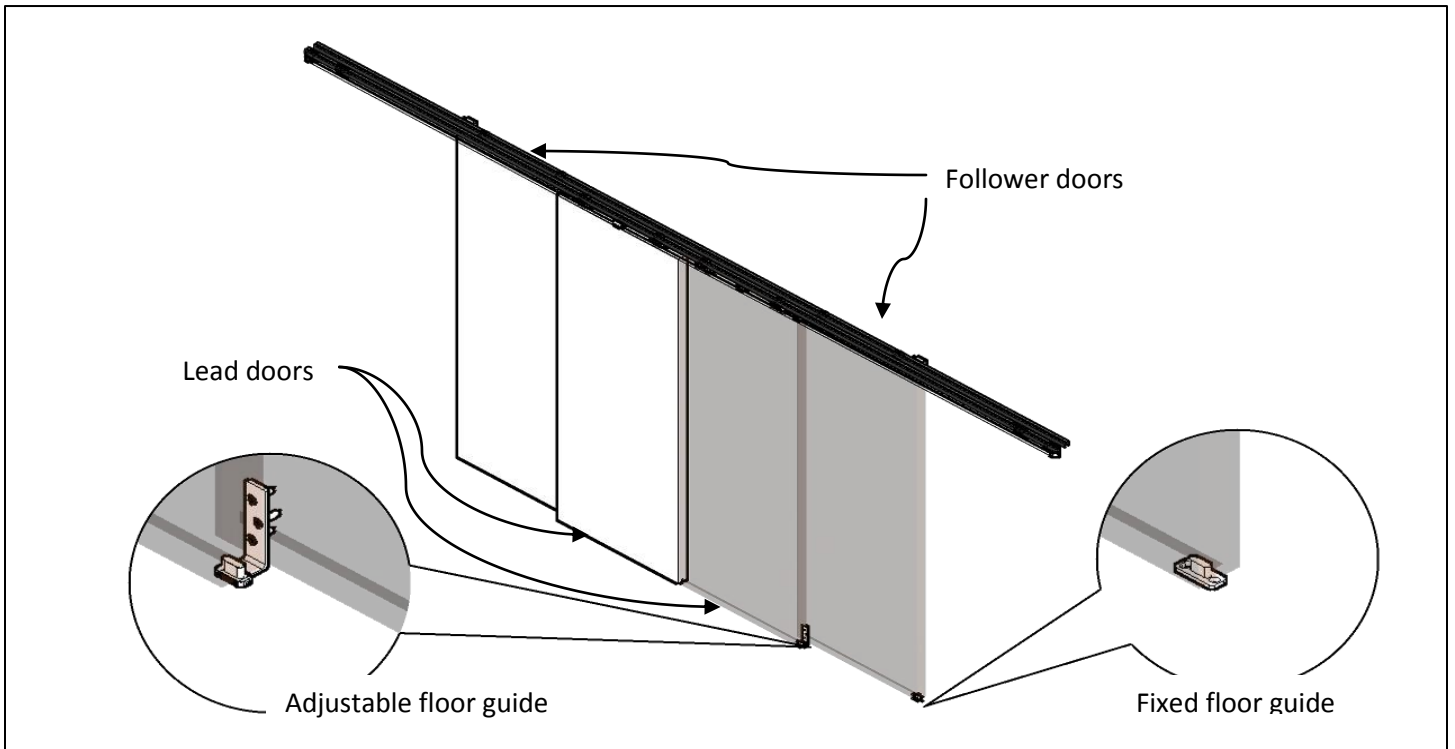

## 12. Align doors with spirit level & position fixed floor guides

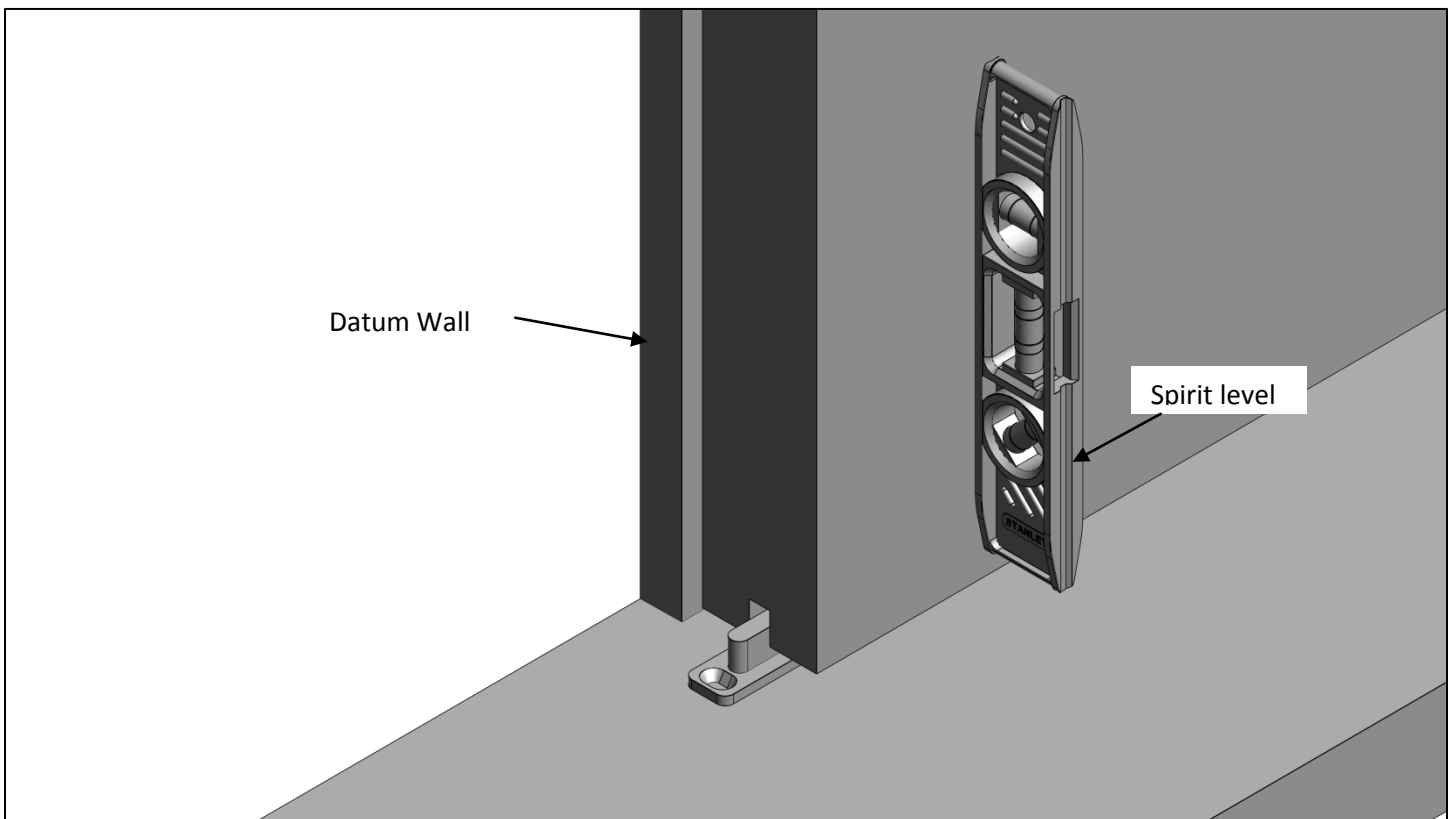

13. Position adjustable floor guide on face of follower door

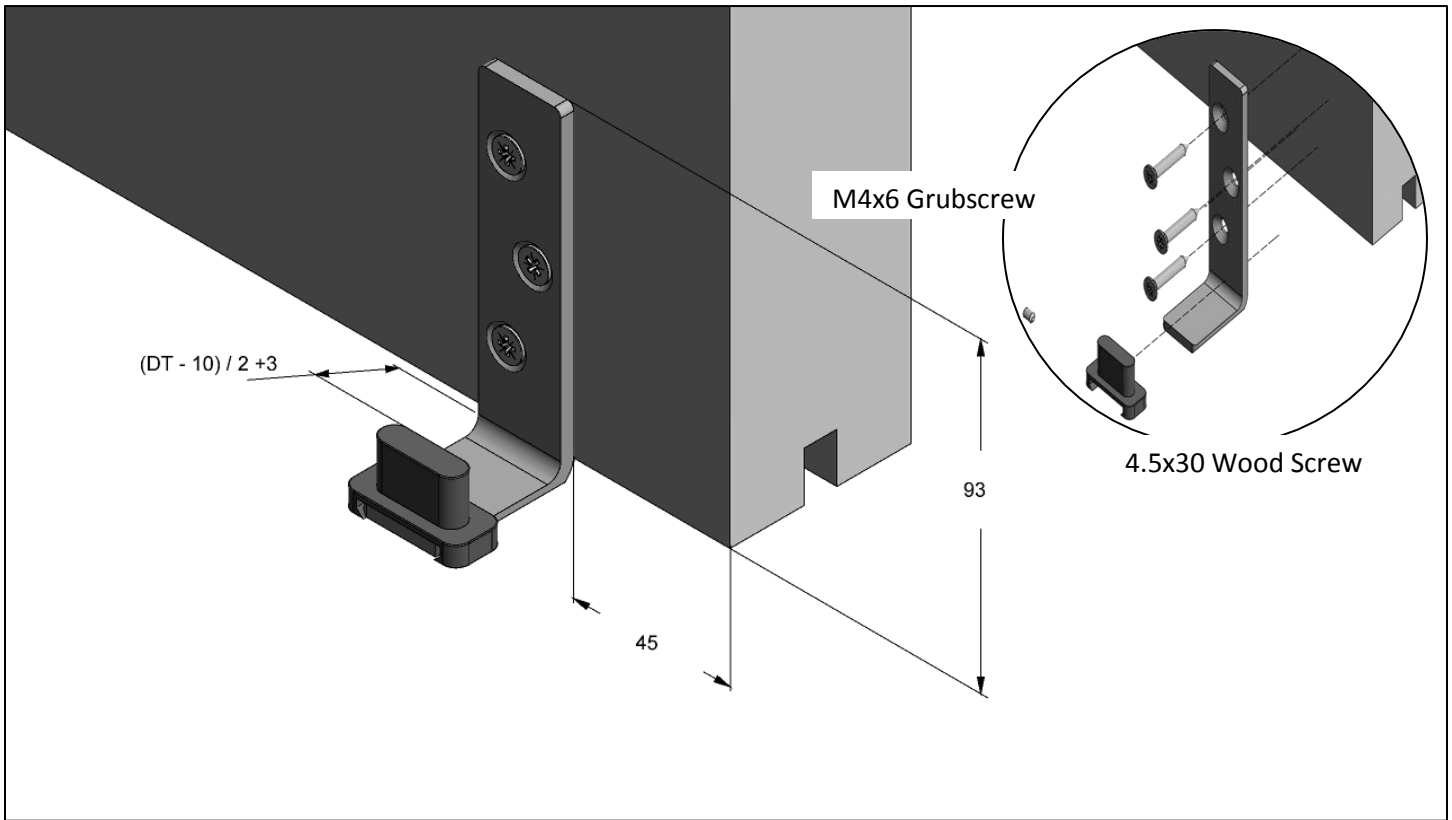

14. Hang doors onto Husky hangers

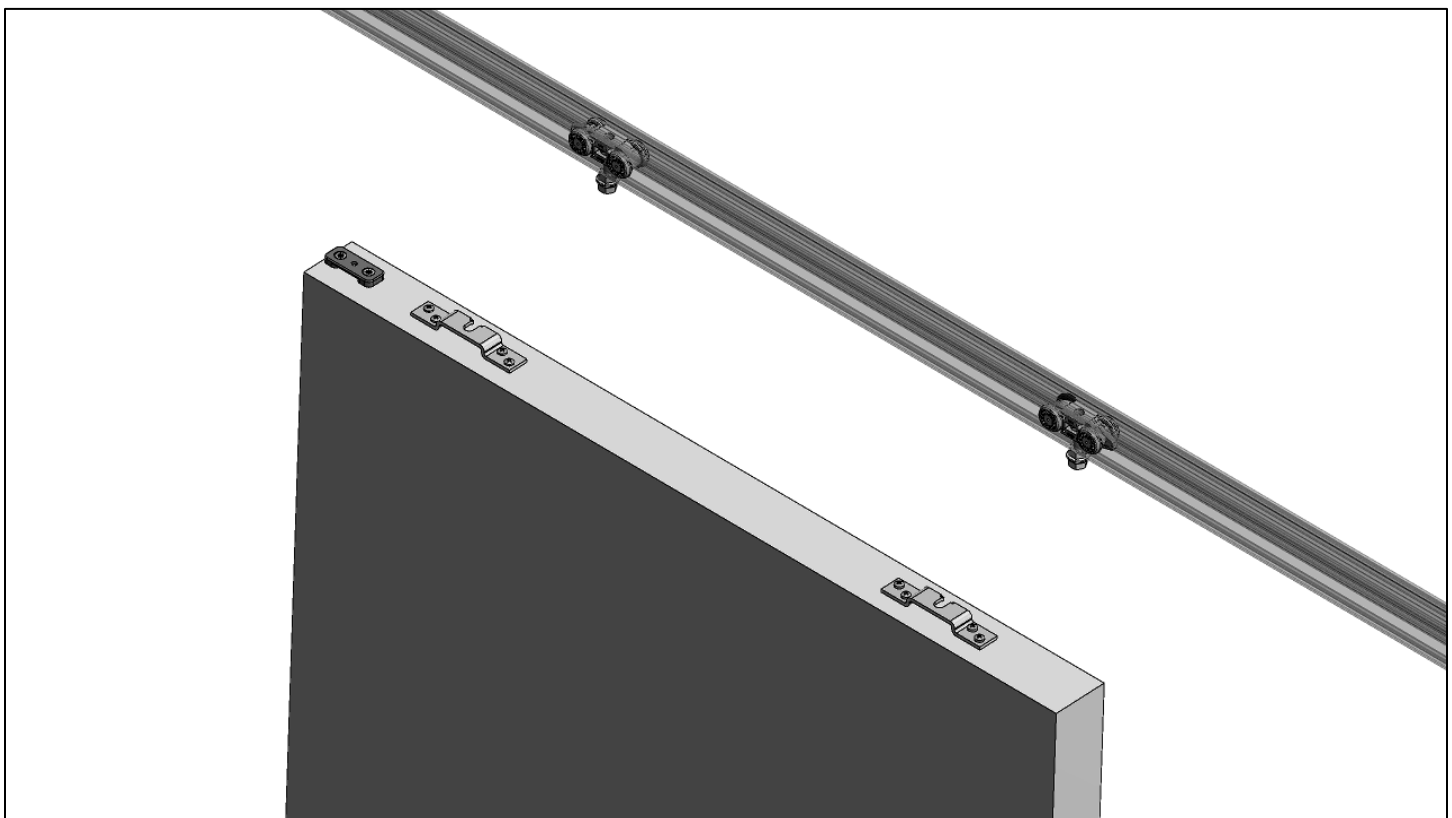

15. Set height & secure doors to hangers

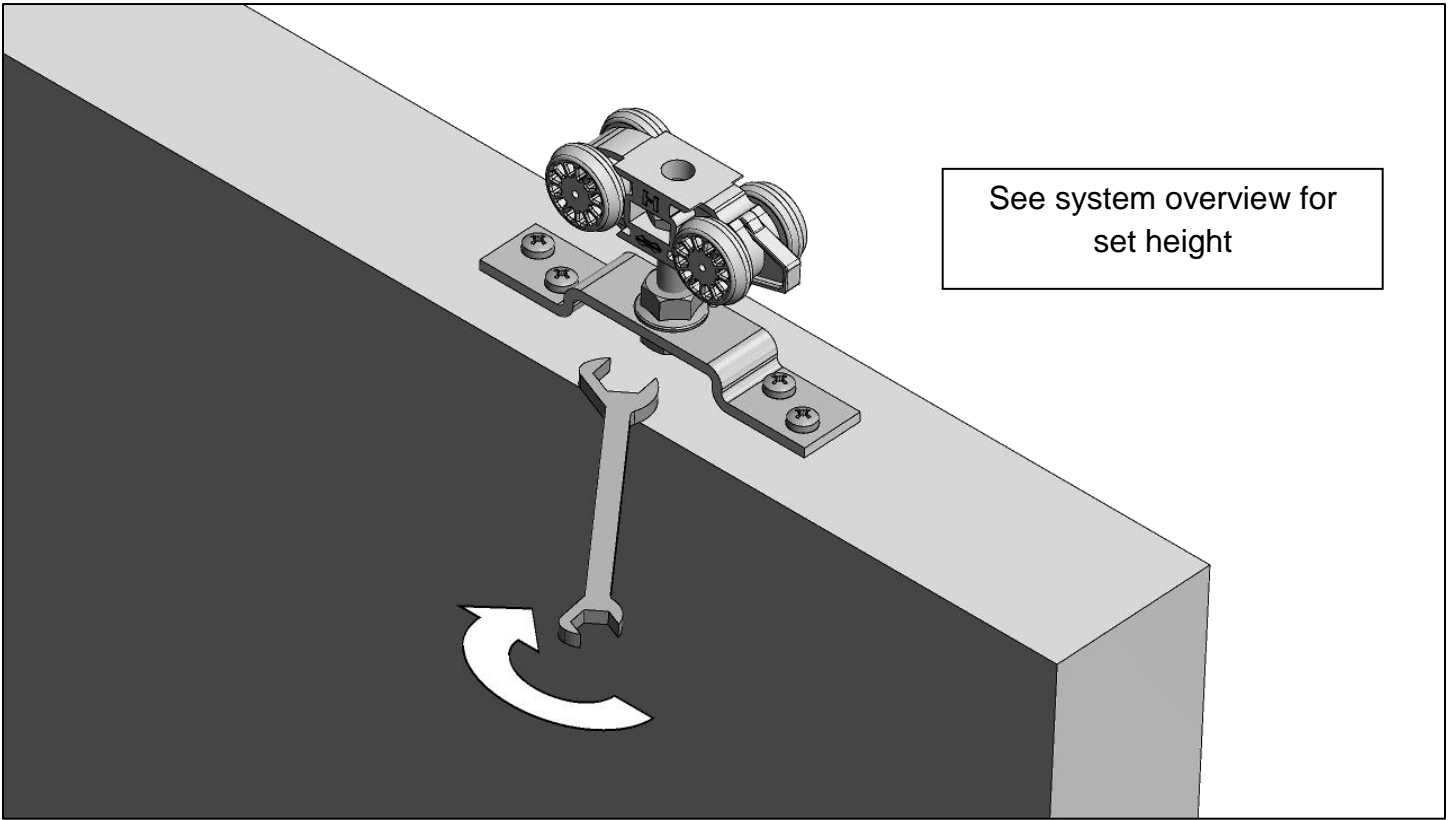

16. Ensure floor guide correctly aligned

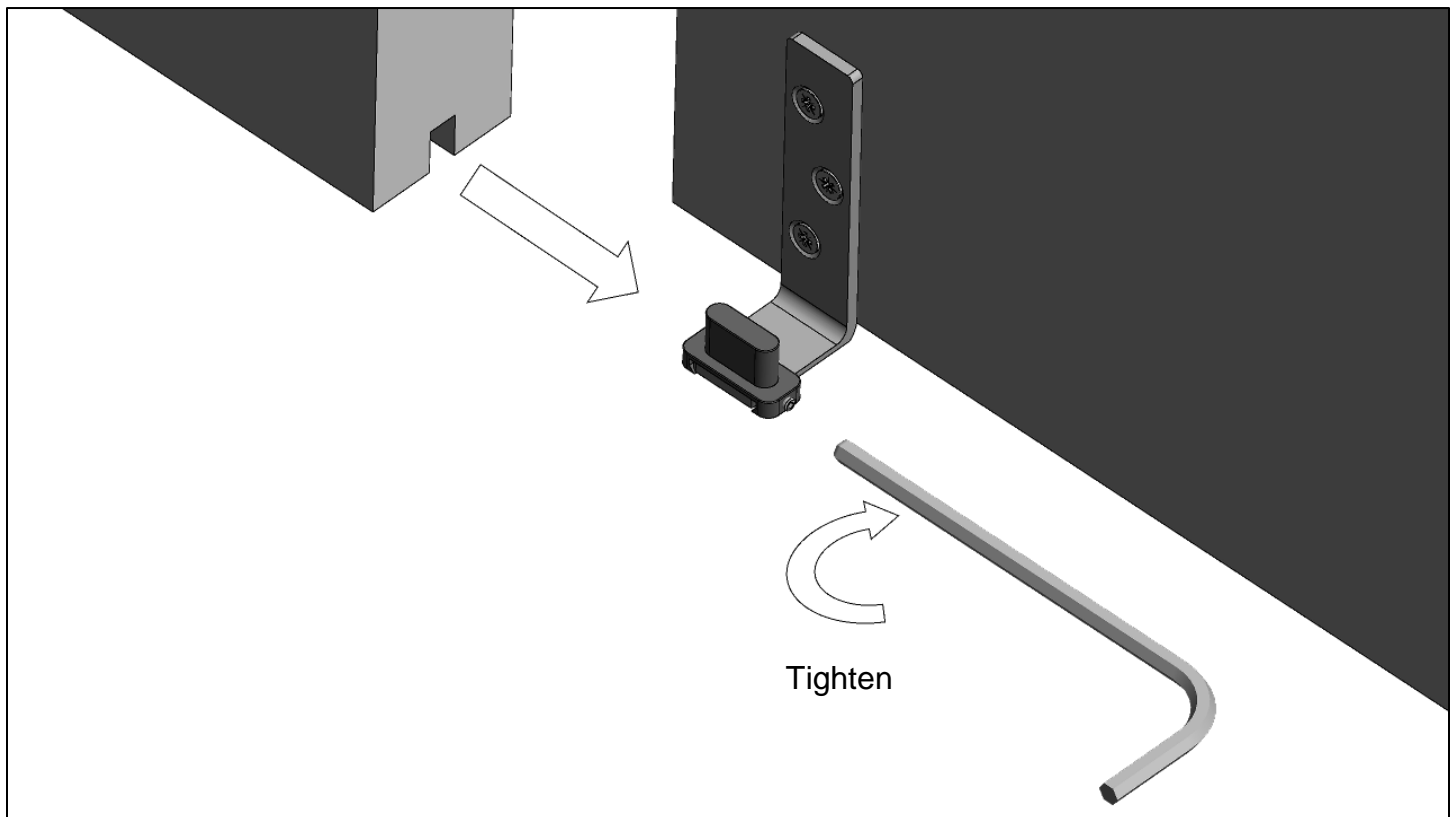

17. Connect doors

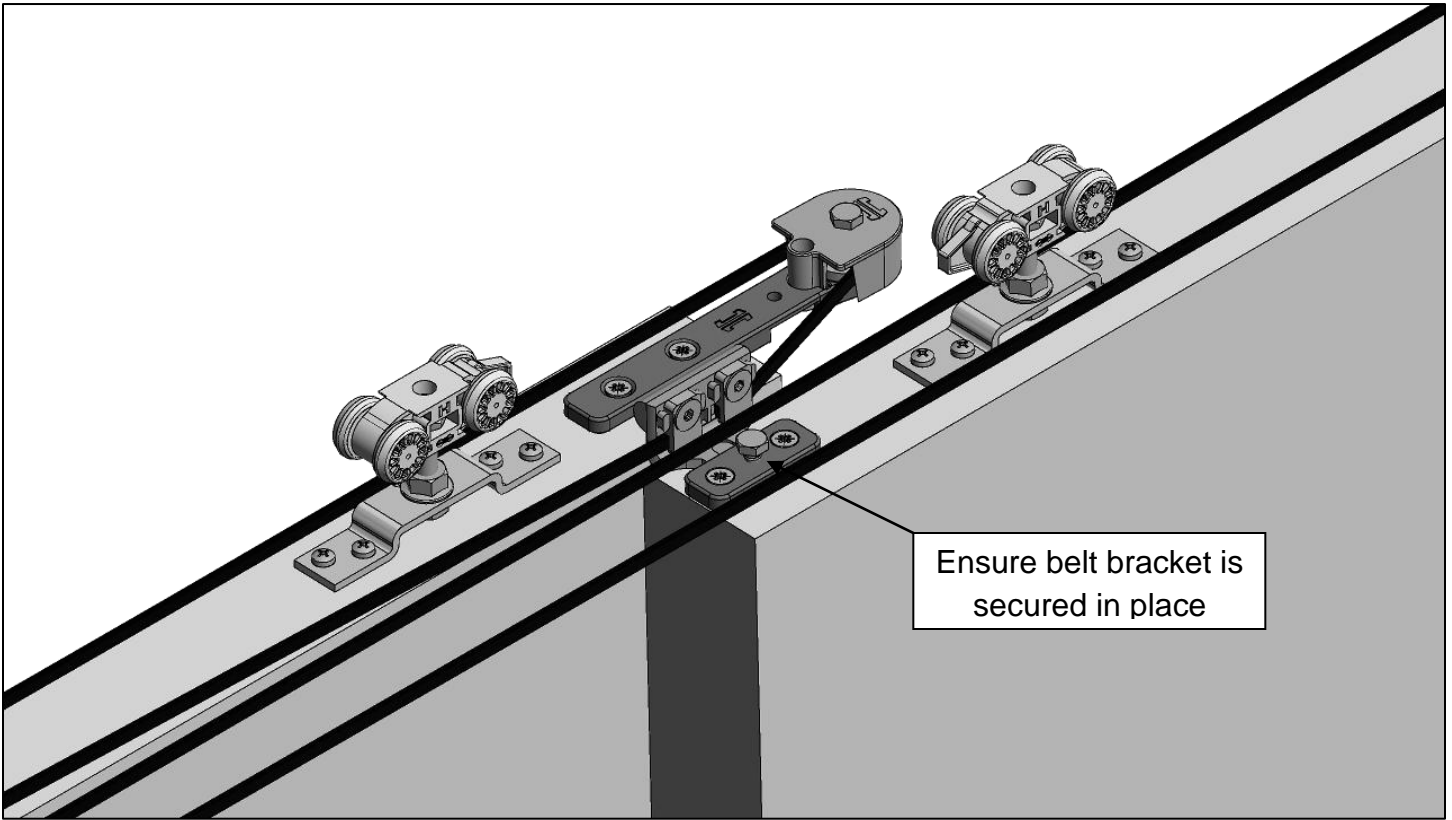

18. 80/4 door belt overview

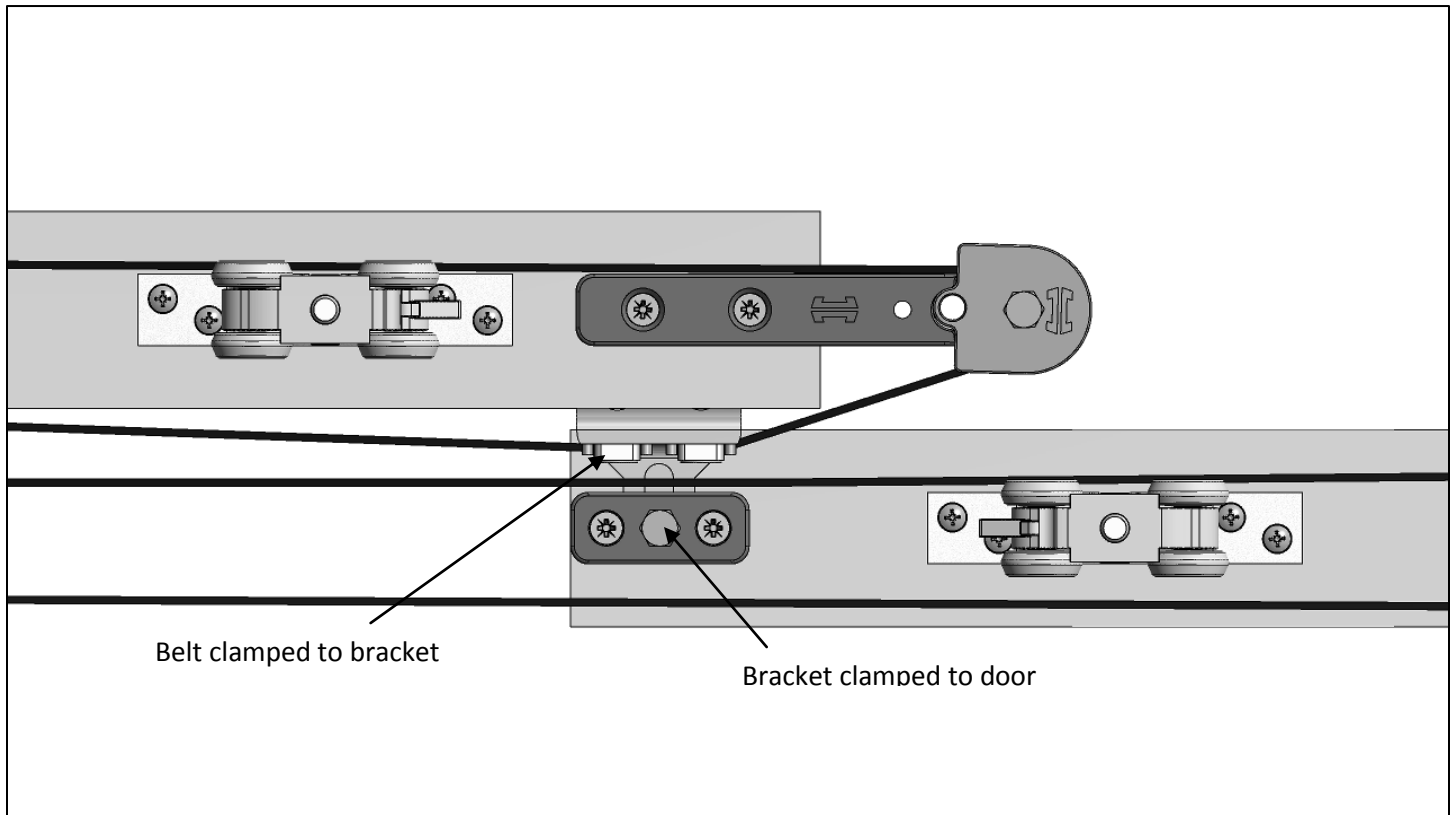

19. With doors fully closed mark position for datum block

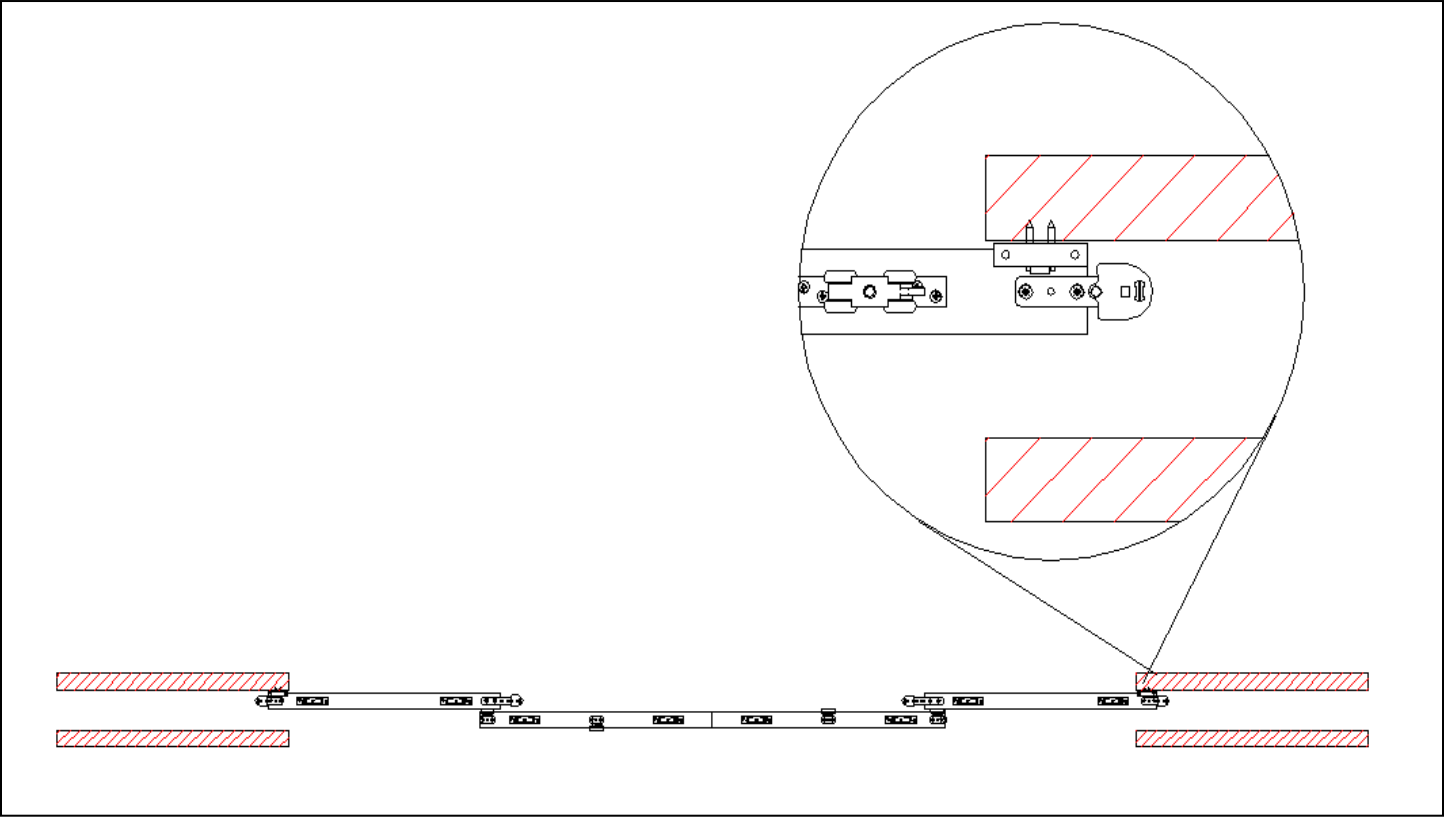

20. Affix datum block – ensuring doors are able to fully traverse the track

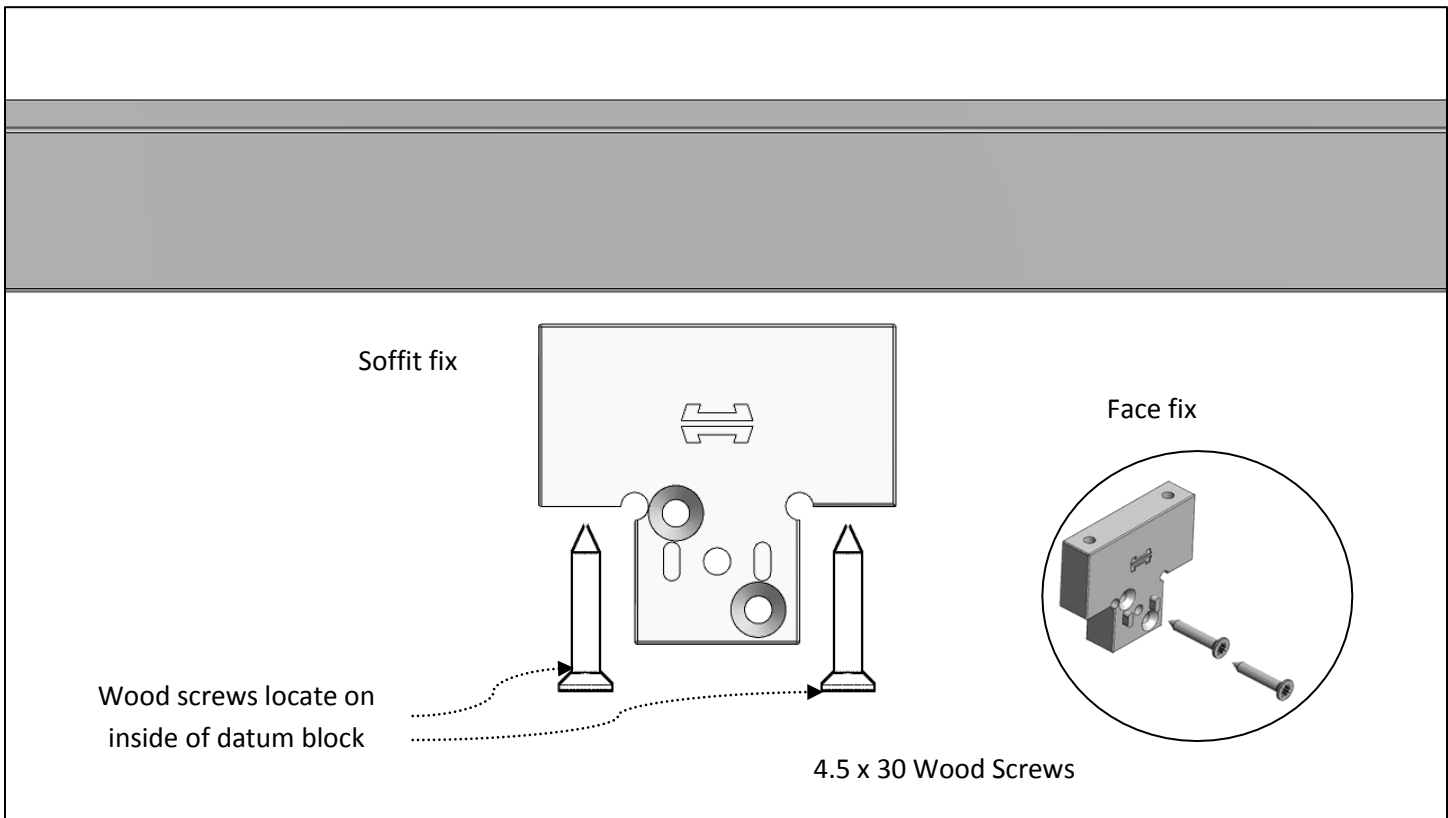

21. Connect belt to datum block

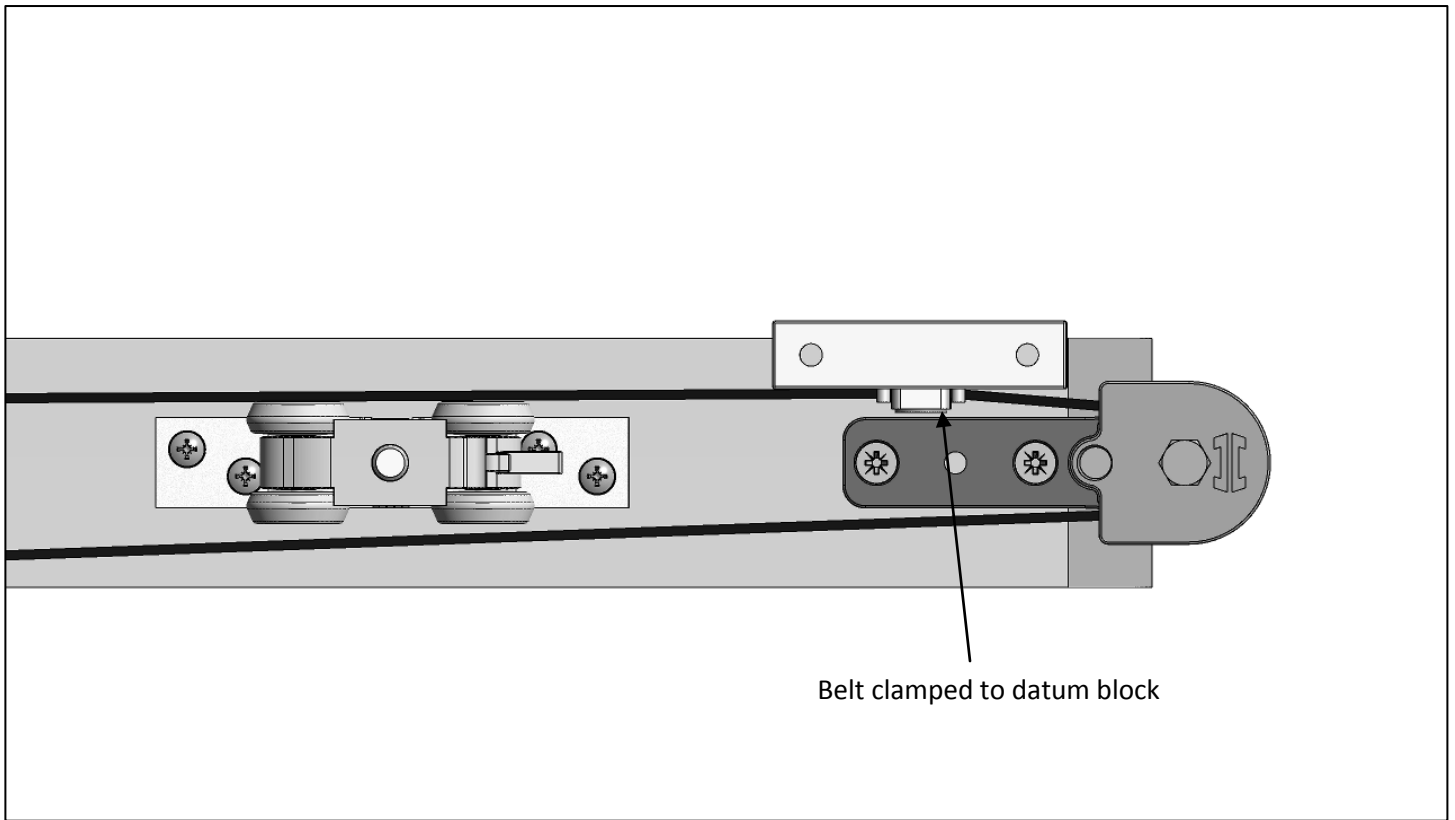

22. Remove bearing cap from tension wheel assembly

23. Loop belt around bearing wheels

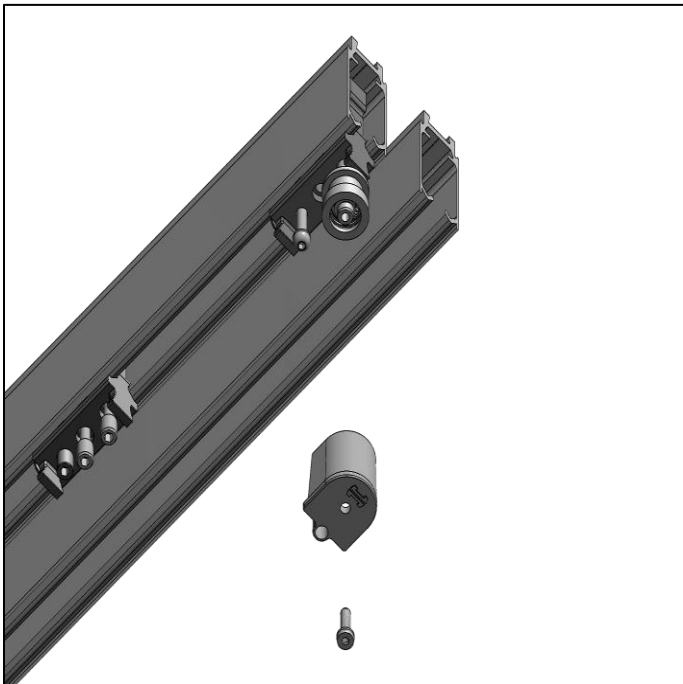

24. Finally connect follower doors to lead doors; ensuring belt joint brackets are securely connected

